

Journal of Civil Engineering and Construction Technology

Volume 5 Number 5 August 2014

ISSN 2141-2634



*Academic
Journals*

ABOUT JCECT

Journal of Civil Engineering and Construction Technology (ISSN 2141-2634) is published monthly (one volume per year) by Academic Journals.

Journal of Civil Engineering and Construction Technology (JCECT) is an open access journal that provides rapid publication (monthly) of articles in all areas of the subject such as surveying, environmental engineering, hydrology, soil mechanics, shear moments and forces etc. The Journal welcomes the submission of manuscripts that meet the general criteria of significance and scientific excellence. Papers will be published shortly after acceptance. All articles published in JCECT are peer-reviewed.

Contact Us

Editorial Office:

jcect@academicjournals.org

Help Desk:

helpdesk@academicjournals.org

Website:

<http://www.academicjournals.org/journal/JCECT>

Submit manuscript online

<http://ms.academicjournals.me/>

Editors

Dr . George Besseris

*El of Piraeus, Greece
Argyrokastrou 30, Drosia, 14572,
Attica Greece*

Prof. Xiaocong He

*Faculty of Mechanical and Electrical Engineering
Kunming University of Science and Technology
253 Xue Fu Road, Kunming
China*

Prof. Jean Louis Woukeng Feudjio

*Department of Mathematics and Computer Science
University of Dschang, P.O. Box 67 Dschang
Cameroon*

Dr. P.Rathish Kumar

*Department of Civil Engineering,
National Institute of Technology, Warangal 506 004
Andhra Pradesh, India. PhNo
India*

Prof. Waiel Fathi Abd EL-Wahed

*Operations Research & Decision Support
Department
Faculty of Computers and Information
El-Menoufia University, Shiben EL-Kom
Egypt*

Prof. JM Ndambuki

*Department of Civil Engineering and Building
Vaal University of Technology
Private Bag X021
Vanderbijlpark 1900
South Africa*

Dr. Dipti Ranjan Sahoo

*Department of Civil Engineering
Indian Institute of Technology
Hauz Khas, New Delhi-110016,
India.*

Dr. Messaoud Saidani

*Faculty Postgraduate Manager
Faculty of Engineering and Computing
Coventry University
Coventry CV1 5FB, England
UK.*

Dr. Mohammad Arif Kamal

*Department of Architecture
Zakir Hussain College of Engineering Technology
Aligarh Muslim University
Aligarh -202002
INDIA*

Editorial Board

Dr. Ling Tung-Chai,

*The Hong Kong Polytechnic University,
Department of Civil and Structural Engineering,
Faculty of Construction and Land Use,
HungHom, Kowloon, Hong Kong.*

Dr. Miguel A. Benítez,

*Project Manager,
Basque Center for Applied Mathematics (BCAM),
Bizkaia Technology Park, Building 500,
E-48160 Derio, Basque Country, Spain.*

Dr. Shehata Eldabie Abdel Raheem,

*Structural Engineering,
Civil Engineering Department,
Faculty of Engineering,
Assiut University, Assiut 71516,
Egypt.*

Dr. Zhijian Hu,

*Department of Road and Bridge Engineering,
School of Communication,
Wuhan University of Science and Technology,
Wuhan, 430063, China.*

Dr. Mohd Rasoul Suliman,

*Prince Abdullah Bin Ghazi Faculty of Science & Information
Technology, Al-Balqa Applied University, Jordan.*

Dr. Paul Scarponcini PE,

*Geospatial and Civil Software Standards,
66 Willowleaf Dr., Littleton, CO 80127,
USA.*

Dr. Rita Yi Man Li,

*Hong Kong Shue Yan University
North Point, Hong Kong.*

Dr. Alaa Mohamed Rashad,

*Building Materials Research and Quality Control Institute,
Housing & Building National Research
Center, 87 El-Tahrir St., Dokki, Giza 11511,
P.O.Box: 1770 Cairo, Egypt.*

Dr. Alaa Mohamed Rashad Abdel Aziz Mahmoud,

*Housing and Building National Research center,
87 El-Tahrir St., Dokki, Giza 11511,
P.O.Box: 1770 Cairo, Egypt.*

Dr. Nikos Pnevmatikos,

*Greek Ministry of Environment,
Urban Planning and Public Works,
Department of Earthquake Victims and Retrofitting
Services, Greece.*

Prof. Karima Mahmoud Attia Osman,

6 Zahraa Naser City, Cairo, Egypt.

Dr. Lim Hwee San,

*99E-3A-10, I-Regency Condominium, Jalan Bukit Gambir,
11700, Penang, Malaysia.*

Dr. Jamie Goggins,

*Civil Engineering, School of Engineering and Informatics,
National University of Ireland, Galway, Ireland.*

Dr. Hossam Mohamed Toma,

*King Abdullah Institute for Research and Consulting Studies,
King Saud University, P.O. Box 2454,
Riyadh 11451, Saudi Arabia.*

Dr. Depeng Chen,

*School of Civil Engineering,
Anhui University of Technology,
59#, Hudong Road, Maanshan, 243002,
China.*

Dr. Srinivasan Chandrasekaran,

*Room No. 207, Dept of Ocean Engineering ,
Indian Institute of Technology Madras, Chennai,
India.*

Prof. Amir Alikhani,

*Ministry of Oil, Harbour organization, and minister of
Energy Tehran, Iran.*

Dr. Memon Rizwan Ali,

*Department of Civil Engineering,
Mehran University of Engineering & Technology,
Jamshoro.*

Prof. Murat Dicleli,

*Department of Engineering Sciences,
Middle East Technical University,
06531 Ankara, Turkey.*

Journal of Civil Engineering and Construction

Table of Contents: Volume 5 Number 5 August 2014

ARTICLES

Research Articles

- | | |
|---|-----------|
| Fire resistance of reinforced concrete rigid beams | 35 |
| Mohammed Mansour Kadhum | |

Full Length Research Paper

Fire resistance of reinforced concrete rigid beams

Mohammed Mansour Kadhum

Civil Department, College of Engineering, Babylon University, Iraq.

Received 1 April, 2014; Accepted 4 August, 2014

The effect of burning by fire flame on the behavior and load carrying capacity of rectangular reinforced concrete (RC) rigid beams is addressed in this paper. Reduced scale beam models (which are believed to resemble as much as possible field conditions) were suggested. Five end restrained beam specimens of casting and testing. The specimens were subjected to fire flame temperatures ranging from (25-750°C) at age of 60 days, two temperature levels of 400 and 750°C were chosen with exposure duration of 1.5 h. The rectangular reinforced concrete beam (2250×375×375 mm) (length×width×height respectively) were cast and subjected to fire. Test results indicate remarkable reduction in the ultrasonic pulse velocity and rebound number of the rigid beams cooled in water were (2-5%) more than the rigid beam specimens cooled in air. Load-deflection curves indicate deleterious response to the fire exposure. Also, it was noticed that the maximum crack width increases with increasing fire temperature.

Key words: Reinforced concrete (RC), rigid beams, fire flame, cracking, nominal moment capacity, fire resistance.

INTRODUCTION

Reinforced concrete (RC) structural systems are quite frequently used in high rise buildings and other built infrastructure due to a number of advantages they provide over other materials. When used in buildings, the provision of appropriate fire safety measures for structural members is an important aspect of design since fire represents one of the most severe environmental conditions to which structures may be subjected in their life time. The basis for this requirement can be attributed to the fact that, when other measures for containing the fire fail, structural integrity is the last line of defense (Kodur and Dwaikat, 2008).

One of the problems confronting buildings is the

exposure to elevated temperatures, hence, should be provided with sufficient structural fire resistance to withstand in such circumstances, or at least give occupants time to escape before strength and, or stability failure ensue. In structural design of buildings, in addition to the normal gravity and lateral loads, it is, in many cases necessary to design the structure to safely resist exposure to fire. However, it is usually necessary to guard against structural collapse for a given period of fire exposure (Shetty, 1988). The properties of the constituent materials of RC beams, concrete and steel, in terms of strength and stiffness are progressively reduced by the increasing temperature. Modulus of elasticity and

shear modulus decrease with the increase of temperature (Gruz, 1966). Numerous studies have investigated the effects of fire on concrete (Smith and Harmathy, 1979), whereas other has examined the effects of fire on steel (Kong et al., 1983). The properties of the constituent materials of RC beams, concrete and steel, in terms of strength and stiffness are progressively reduced by the increasing temperature. Modulus of elasticity and shear modulus decrease with the increase of temperature (Gruz, 1966). Numerous studies have investigated the effects of fire on concrete (Smith and Harmathy, 1979), whereas other has examined the effects of fire on steel (Uddin and Culver, 1975).

Analyzing the bearing capability of RC beams after sustaining fire requires the knowledge of temperature distribution in the cross sections. This is determined by the thermal properties of the material, such as the heat capacity and thermal conductivity. A simple thermal model, which is generally to all beams with a rectangular cross section, has been assessed in a separate serious of studies which were also reported in a previous paper (Hsu et al., 2006). The modeling results achieved reasonable agreement with isothermal contours obtained by (Lin, 1985) who analyzed the temperature distribution of pure concrete according to the time-temperature curve of standard fire. Compared with numerous investigations regarding the behavior of RC members in fire (Huang 2011, Choi and Shin, 2011), relatively limited studies were directed towards the residual properties of RC members after fire. El-Hawary et al. 1996, performed experiments on the flexural strength of three RC simply supported beams and studied the impact of fire durations on the ultimate load and deflection. Moreover, the shear strength of simply supported RC beams was found highly dependent on the fire durations and thicknesses of concrete cover (El-Hawary et al., 1997). Phani et al. (2010) tested twelve simply supported RC beams with different concrete grades, fire durations and stirrup spacings. The effect of fire duration was found to be the key factor by the authors. Five loaded RC beams were heated to 800°C for 30 min by Kowalski and Krol (2010). The test results show that the residual bearing capacity of specimens decreased significantly with the failure mode of concrete crushing. Considering the extensive fire test, some analysis methods were proposed to model the residual mechanical properties of RC beams after fire exposure. Hsu and Lin (2006) used finite difference method to model the temperature history of RC beams subjected to fire. Additionally, the structural analysis, on the basis of lumped method, was performed to calculate the residual bending moment, shear strength and elastic modulus of RC beams after fire. The goal of this research work was first to investigate the structural behavior of RC rigid beams under fire conditions. Another purpose was to determine the residual ultimate bending moments of RC beams after fire damage. Therefore, the current research proposes a reinforced concrete rigid beams

model which resembles the simulation of the state of stress which the reinforced concrete rigid beams are subjected to during fire in laboratory.

EFFECT OF FIRE ON REINFORCED CONCRETE STRUCTURE

Although severe fire may cause significant damage to reinforced concrete (RC) structures, collapse of RC structure, as the result of fire-damage, is rarely happened. Thus, an effective fire damage evaluation method, serviced as the basis of rehabilitation, is always necessary for a fire damaged RC structure. ACI Committee, 1994 reported the guide for determining the fire resistance of concrete elements. It was a summary of practical information to be used by engineers and architects.

Hsu and Lin (2006) investigated residual bearing capabilities of five-exposed reinforced concrete beams. The analysis method includes combining thermal and structural analyses for assessing the residual bearing capabilities, flexural and shear capacities of reinforced concrete beams after fire exposure. The thermal analysis uses the finite difference method to model the temperature distribution of a reinforced concrete beam maintained at high temperature. The structural analysis, using the lumped method, is utilized to calculate the residual bearing capabilities, flexure and shear capacities of reinforced concrete beams after fire exposure. This novel scheme for predicting residual bearing capabilities of fire-exposed reinforced concrete beams is very promising in that it eliminates the extensive testing otherwise required when determining fire ratings for structural assemblies.

Kodaira et al. (2004) studied the behavior of composite beams composed of rolled steel profile concreted between flanges during a fire by conducting a fire resistance test with different cross sections and load ratios, by numerical analysis. The results they obtained are as follows:

(i) In steel-concrete composite beams which were simply supported and to which positive bending moment was applied, deformations were downward in the early period of fire, and then the deformation rate decreased once but increased again as heating was continued, leading to the limit of fire resistance.

The fire resistance of steel-concrete composite beams increased when the applied bending moment ratio decreased. The fire resistance time was affected by the size of the cross-section, whether steel-concrete composite beams were connected to the reinforced concrete floor or not, as well as by the applied bending moment ratio. For simply supported RC members subjected to fire, tensile concrete is directly exposed to fire from underneath, while compressive concrete

generally has little chance to a fire and will suffer much less damage than the tensile region. Considering tensile concrete normally contributes little to the flexural strength of slab or beam, softening of steel rebars at elevated temperatures is believed to be the crucial factor of strength degradation in such case. After fire, with the steel rebars regaining most of their strength at ambient temperature (Elghazouli et al., 2009), a simply supported RC member can recover considerably its initial flexural strength. As to continuous RC members, the situation will be different. The compressive concrete in the hogging moment region of continuous member has equal chance to be directly exposed to fire. Unlike the heat impact on steel rebar, fire damage on compressive concrete is unrecoverable and should not be neglected when evaluating damage level of RC members (Schneider, 1988; Bazant and Kaplan, 1996).

MATERIALS AND METHODS

The properties of materials used in any structure are of considerable importance (Neville, 1995; ACI Committee 211, 1997). The properties of materials used in the current study are presented in this work. Standard tests according to the American Society for Testing and Materials (ASTM) and Iraqi specifications IQS were conducted to determine the properties of materials. Tasluga-Bazian Ordinary Portland cement (O.P.C) (ASTM Type I). This cement complied with the Iraqi specification (IOS, No.5:1984a,b). Well-graded natural sand from Al-Akhaidher region through sieve size (9.5 mm) to separate the aggregate particles of diameter greater than 9.5mm. The gravel was sieved at sieve size of (20 mm). The sand and gravel were then washed and cleaned with water several times, then it were spread out and left to dry in air, after which it were ready for use. Galvanized welded wire meshes were used throughout the test program. Deformed steel bars of diameters (\varnothing 8 mm) and (\varnothing 10 mm) were used as reinforcement.

Mix design and proportions

The concrete mix was designed according to American mix design method (ACI 211.1-91) specification. The proportions of the concrete mix are summarized in Table 1. The RC beams with same mix proportion (Cement: Water: Sand: Gravel=1: 0.45: 1.67: 2.80) were made in a single batch. The specimens were compacted using a vibrating rod and cured in a moist environment at room temperature at 23°C and 95% relative humidity for a period of fourteen days after casting, and then placed in a natural environment. The specimens were tested after 60 days. After 28-day curing, tests on concrete gave the mean compressive cube strength was 38.8 MPa at room temperature. The corresponding modulus of elasticity was 29.4 GPa. The yield and ultimate strengths of steel bars were 364 and 542 MPa and the modulus of elasticity of steel bars were tested to be 200 GPa for beams.

Design and fire test of the specimens

Totally five RC rigid beams were fabricated for the experimental investigations. All the RC rigid beams were, 2250 mm length, with a square cross-section 375×375 mm (Figure 1). The reinforcing bars were cut to the desired length, and 90° hooks were formed at the

ends of each bar. Stirrups made from 8 mm diameter plain bars were provided to prevent the shear failure. Fire tests were undertaken in a gas furnace at the fire laboratory of Babylon University- College of Engineering. All the specimens were heated on two faces, that is, from underneath and inside lateral faces fire exposure of rigid beams. The experimental work was carried out to decide upon the temperature range and duration of burning. It was decided to limit the maximum exposure to fire flame to about 400 and 750°C, with duration of exposure to fire flame of 1.5 h which cover the range of situation in the majority of elevated temperature test.

After greasing the moulds of the rigid beams specimens, reinforcement bars were held carefully in their position inside these moulds. In order to get a cover, small pieces of steel were placed at sides of the rigid beams reinforcement. Figure 1 shows the dimensions and details of the reinforcement of rigid beam specimens. Figure 2a, b and c show the formwork was strike after 7 days from casting and the beams were covered with wetted hessian and polythene sheets during 7 days. The hessian sheets were wetted two times a day during the curing.

Two cooling methods were employed for the burning RC specimens. At the end of the sustained periods at the corresponding maximum temperatures, the network methane burner stopped off and removed from the RC specimens. Some of very large water tank and kept in water for 24 h prior to testing. The remaining RC specimens were cooled in air at the laboratory conditions for 24 h prior to testing. Both water quenched and air cooled beams were tested under concentrated loads were applied to the RC rigid beams through hydraulic jacks and steel girders, as shown in Figure 4. The loading regime for beams was similar. The specimens were weighted at different stages of burning and cooling.

Reinforced concrete rigid beams and testing procedure

The RC rigid beam specimens were tested using a load cell of maximum capacity of (150 Tons) at the age of 60 days. The load was applied using steel beam that divided the load to two equal point loads. The beam specimens were subjected to increasing load in increments of 5-10 kN, until final failure. The load was the burning RC rigid beams were quenched in water at 25°C in a stopped at each increment for two minutes for observation. Load was applied with a hydraulic jack at four points on the beam. Vertical deflection was measured at mid centre using an LVDT transducer.

The mid-span deflection of the RC beam specimens exposed to fire are resulting from loading to 25% of ultimate load (18.5 kN) before burning, loading 25% and applied fire flame for exposure period 90 min, thereon, cooled by water or air then residual ultimate loading after burning was applied until failure. While, for beam specimens without burning the mid-span deflection is resulting from applied load only. Testing continued until the reinforced concrete beam shows a drop in load capacity with increasing deformation.

Figure 3 shows a schematic diagram for loading arrangement. The specified (target) fire temperature was reached by mounting the fire subjecting burners by a sliding arm to control the fire distance to the surface of the beam specimens, and also by monitoring the fire intensity through controlling the methane gas pressure in the burners. Then, the sliding arm and gas pressure were kept at this position along the period of burning (1.5 h). Linear variable displacement transducers (LVDT) and thermocouples were employed to record vertical displacement and temperature responses. The thermocouples used were "PTFE insulated k type twisted cables". The deflection of the rigid beams exposed to fire are resulting from loading to 25% of ultimate load before burning, loading 25% and applied fire flame, and loading after burning until

Table 1. Mix proportions for the concrete used to cast each rigid beam.

W/c ratio	Mix proportion kg/m ³				Slump (mm)
	Water	Cement	Sand	Gravel	
0.45	195	435	725	1215	60

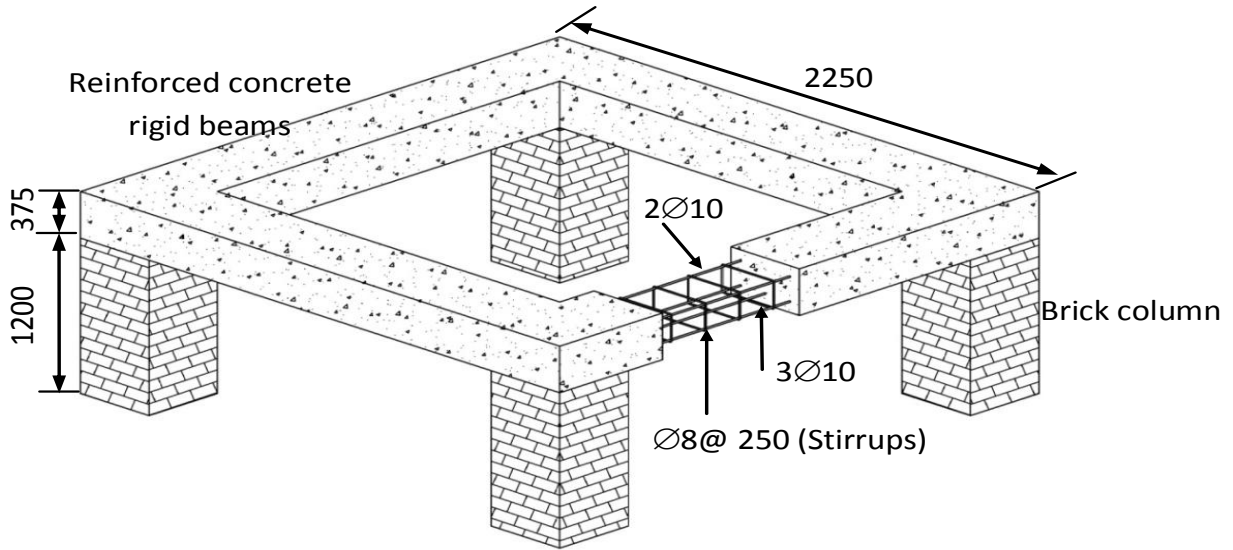

Figure 1. Layout and dimension of rigid beams. Dimensions in mm.



Figure 2. (A) The wood formwork of the rigid beams; (B) The rigid beams after lifting of the wood formwork; (C) Curing of Rigid beam with the wetted hessian and polythene sheets.

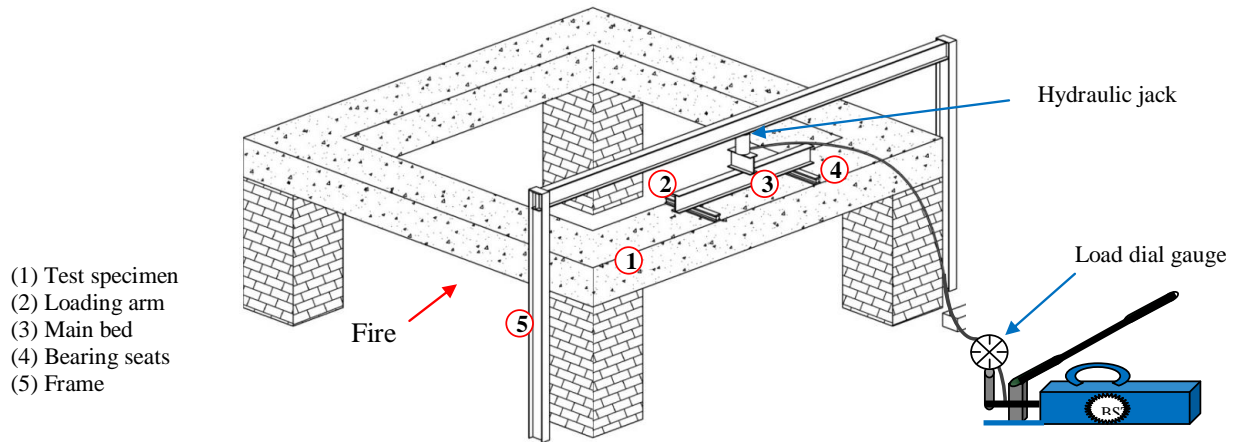

Figure 3. Fire test setup.



Figure 4. Testing of rigid beam specimens under 25% of ultimate load with exposure to fire flame.

Table 2. The test results of ultrasonic pulse velocity and rebound number of RC rigid beams before and after exposure to fire flame.

Type of test	Temperature (°C)			(Va/Vb) Ratio		Type of cooling
	25 A	400 B	750 C	B/A	C/A	
UPV (Km/Sec)	4.62	3.32	2.21	0.72	0.48	Air
		3.10	2.11	0.67	0.46	Water
Rebound number	33.0	26.0	20.6	0.79	0.62	Air
		24.7	18.3	0.75	0.55	Water

Va and Vb Values of test results after and before exposure to fire flame respectively.

failure. Figure 4 shows the rigid beam which was subjected to fire flame under loading. While, for rigid beams without burning the deflection is resulting from applied load only.

RESULTS AND DISCUSSION

Non-destructive and water absorption test results

The ultrasonic pulse velocity (U.P.V) and surface hardness of RC rigid beams was assessed by the "Schmidt rebound hammer" test results are presented in

Table 2. Figures 5 and 6 show the effect of exposure to fire flame on ultrasonic pulse velocity and rebound number respectively for the rigid beams before and after exposure to burning. It can be seen from the figure below that the reductions in the ultrasonic pulse velocity after exposure to fire flame were as follows:

- (i) At 400°C, the reduction in (U.P.V) was (28 and 33%) when rigid beams were cooled by air and water respectively. Whereas, at 750°C the reduction was (52 and 54%) when beams were cooled by air and water

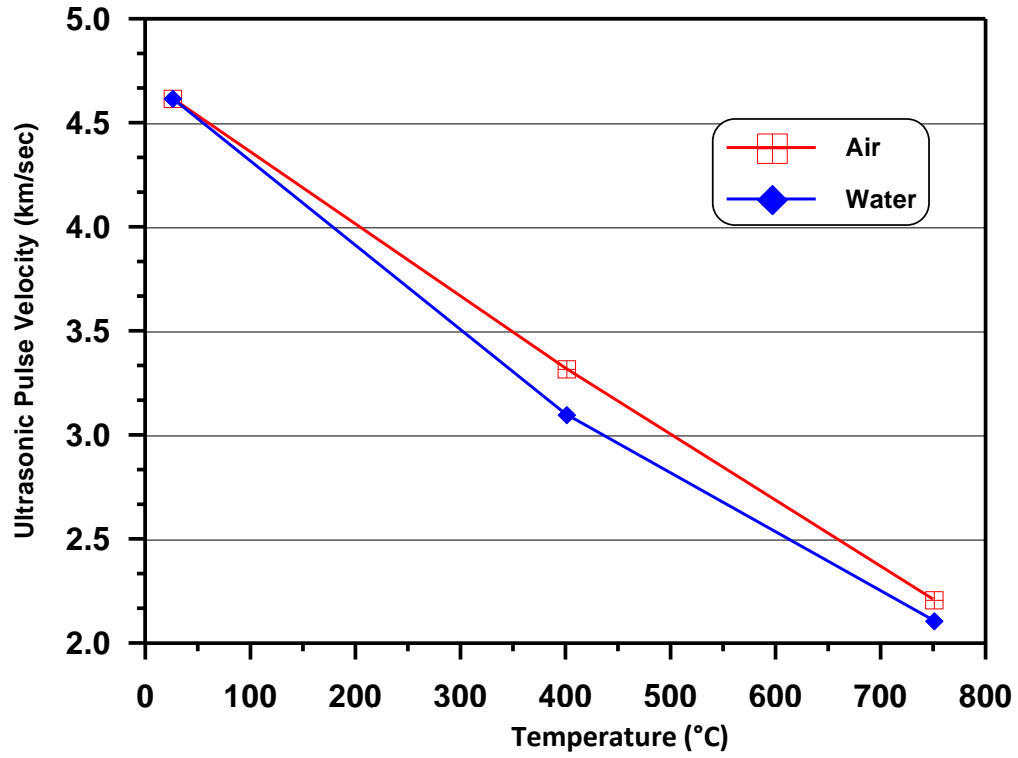

Figure 5. The effect of fire flame on the UPV.

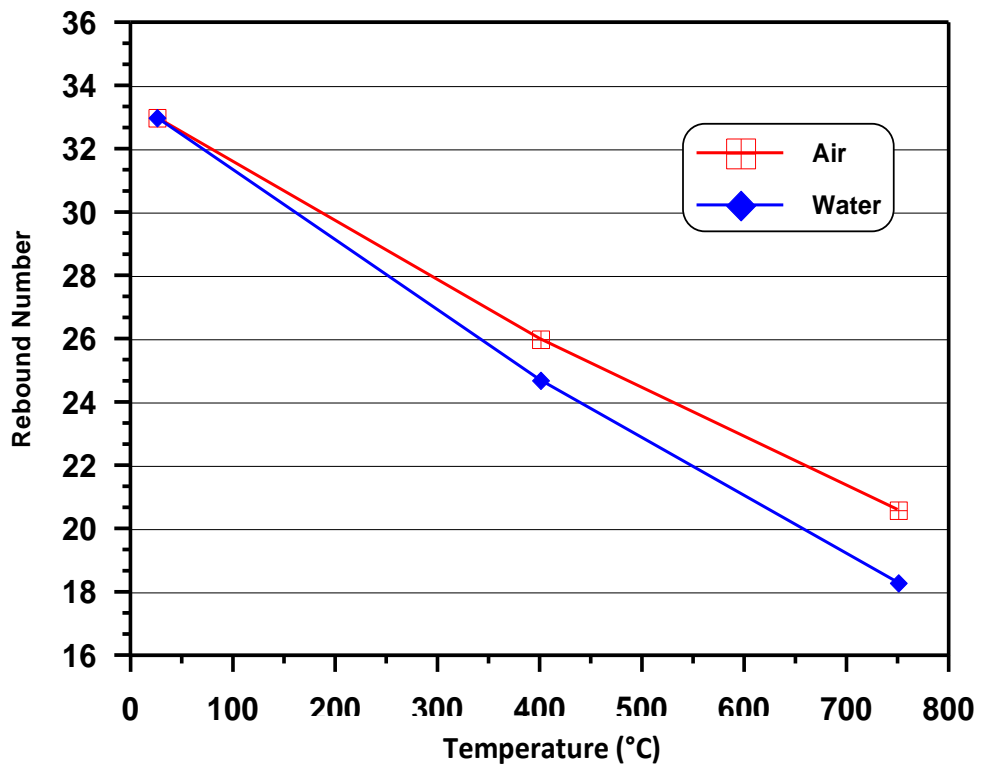

Figure 6. The effect of fire flame on the rebound number.

respectively. The effect of burning by fire flame on rebound number is shown in Figure 6. It can be seen that subjecting the reinforced concrete rigid beams surface to fire causes to decrease the rebound number significantly as follows:

(ii) At 400°C, the reduction in rebound number was (22 and 27%) for beams which were cooled in air and water respectively. Whereas, at 750°C the reduction was (42 and 45%) for beams cooled in air and water respectively.

Removal of water from the pores in the concrete system produced a reduction in pulse velocity for the specimens. Increasing temperatures active a series of reaction in the hardened cement paste, complete desiccation of the pore system followed by the decomposition of hydration products and the destruction of the gel structure in hydrated cement paste. The reduction in rebound number is lower than the relative loss of the pulse velocity. The results indicate that high temperatures have a lesser effect on the hardness of the concrete surface than that on the internal changes within the concrete specimens.

The water absorptions for the RC rigid beams on water quenching were more than that for the corresponding air-cooled RC specimens. Sudden cooling of burning concrete may have created additional micro-cracks leading to increased water absorption. For burning specimens and subjected to water quenching, the water content of concrete after saturation was between (3.43 and 3.62%) of the water content prior to drying. The corresponding value for air cooled concrete was between (2.01 and 2.18%). The specimens fired to 750°C showed the largest value for water absorption in relation to the water loss on heating. These differences in water content indicate that the pore structure and hydration products are affected by the factors such as maximum temperature, cement type and method of cooling.

Effect of burning on load versus deflection results

The load versus mid-span deflection relationship of RC rigid beam specimens which were loaded and with or without exposed to fire flame at the same time was measured during this process are summarized in Table 3 and depicted in Figure 7. Each beam specimen was loaded to 25% of the ultimate load (18.5 kN) before burning for a period of 25 min; then exposed to fire flame temperatures of (400 and 750°C) thereon, cooled by water or natural air and finally the residual ultimate load was applied until failure.

Deflection of these rigid beam specimens, which occurred immediately when they were loaded and subjected to fire flame, this deflection is called immediate deflection or instantaneous deflection. Deflection measurement was taken continually during the test and the rate of increase in deflection was controlled to provide

warning of impending collapse of the beam specimens. From this figure, it can be seen that the increase in the fire temperature has a significant effect on deflection of beam specimens cooled. In addition, it can be noted that the increase in the fire temperature decreases the load carrying capacity and increases deflection in beam specimens. This can be attributed to the fact that heating causes a reduction in beam stiffness, which is essentially due to the reduction in the modulus of elasticity of concrete and the reduction in the effective section due to cracking. These figures reveal that the load-deflection relation of the beam specimens is almost linearly proportional for temperature exposure (400 and 750°C). Also, it can be indicated from the results in this figure that the ultimate load capacity of the rigid beams is adversely influenced by the fire flame exposure and this deleterious effect decreases the ultimate load capacity by about 15-37%. Also the maximum deflection at ultimate load increases by about 37% which shows clearly reduced stiffness behavior.

It is obvious from the results that the values of residual first crack load decrease when the beams are exposed to fire flame except (RB2) which increase by (4.2%) over original first crack load. This increase can be attributed to the general stiffening of the cement gel or the increase in surface forces between gel particles due to the removal of absorbed water. Figure 8 reveals the effect of fire flame on the residual first crack load for the rigid beam specimens.

Figure 9 reveals the comparisons of bearing capacity among the test specimens. It is clear from this figure that there is a reduction in ultimate load capacity after exposure to fire flame, the reduction specimens cooled in water was more than the reduction from the specimens cooled in air. The ultimate bearing capacities of fire damaged beams are slightly lower than that of reference RC rigid beam (RB1).

Verification of building codes provisions

Several existing equations are available to predict the bending moment capacity of RC beams. These equations are selected and used in this study for comparison with the results of the experimental work. These equations are outlined in the Table 4. Where: M_n = Nominal moment, kN.m, $f_{cu} = 0.85f'_c$, The ultimate moment M_u (for design) is $M_u = \phi M_n$ and $\phi = 0.9$.

The test results were utilized to verify the recommendations and design simplifications of the various Building Codes pertaining to bending moment capacity (M_u) design. Table 5 presents the comparison between the experimental results with (ACI and B.S) Codes. The relationship between fire temperature with residual moment capacity and ultimate moment capacity are plotted in Figures 10 and 11.

Table 3. Test results of the first crack load, ultimate load and deflection for rigid beams control and exposed to burning.

Specimen code	Temperature (°C)	First crack load (kN)	Percentage residual first crack load %	Ultimate load capacity (kN)	Max center deflection (mm)	Type of cooling
RB1	25	26.3	100	73.74	9.33	---
RB2	400	27.4	104.2	63.85	10.10	Air
RB3	400	23.2	88.2	56.22	13.24	Water
RB4	750	12.8	48.7	39.00	13.90	Air
RB5	750	8.0	30.4	22.18	14.74	Water

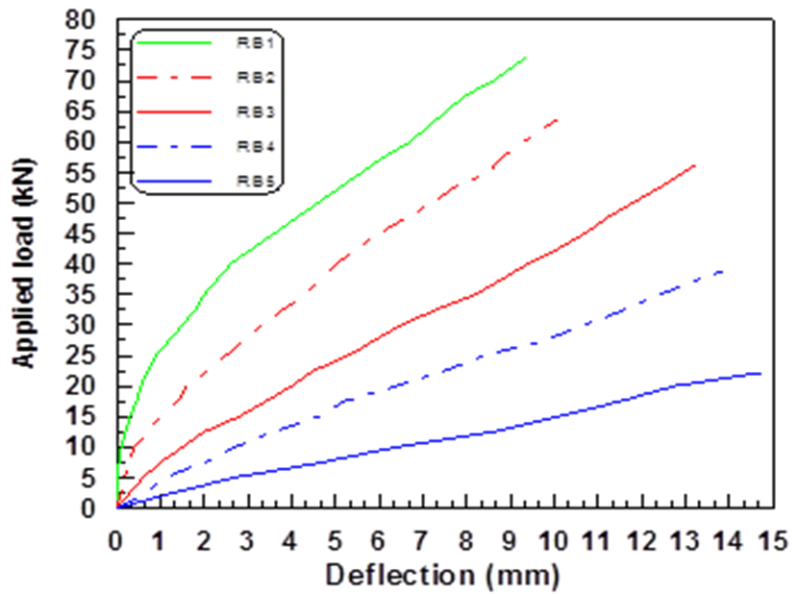

Figure 7. Load deflection curves for the rigid beam specimens.

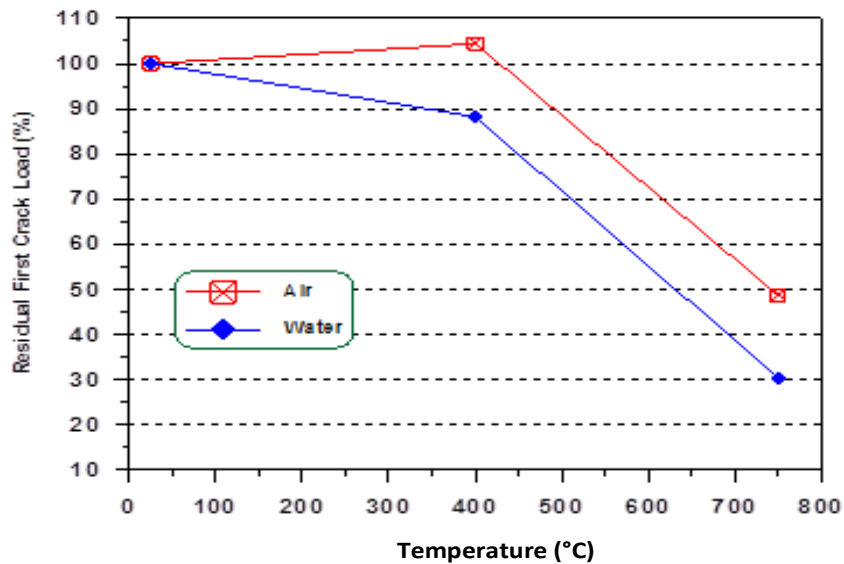

Figure 8. Effect of fire flame on the residual first crack load for the rigid beam specimens.

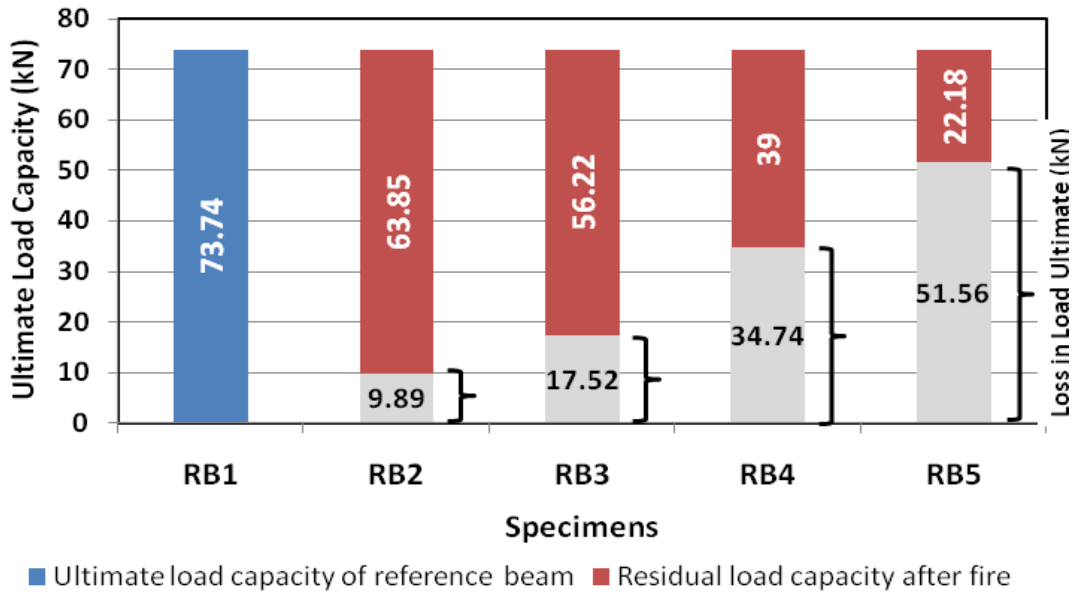

Figure 9. Ultimate load capacities of RC rigid beams.

Table 4. Summary of formulas for predicting moment beam capacity.

Method	Equation	Equation number
ACI-318M-08 Code	$M_n = \phi \rho b d^2 f_y \left(1 - 0.59 \rho \frac{f_y}{f_c} \right)$	1
B.S 8110-97 Code	$M_u = 0.87 f_y A_s \left(d - \frac{f_y A_s}{1.34 f_{cu} b} \right)$	2

Table 5. Ultimate moment capacity from experiment and from (ACI and B.S) Codes for beam specimens.

Specimen code	Cylinder compressive strength (MPa)	Steel yield stress (GPa)	Ultimate load (kN)	Percentage residual moment capacity	M_u (kN.m)			$\frac{M_u(Test)}{M_u(BS)}$	$\frac{M_u(Test)}{M_u(ACI)}$
					Test	BS	ACI		
RB1	24.0	530	142.6	100	35.65	32.78	34.30	1.09	1.04
RB2	19.7	530	124.4	0.87	31.15	32.53	34.06	0.96	0.91
RB3	18.5	530	112.0	0.79	28.00	32.46	33.92	0.86	0.83
RB4	12.4	408	72.8	0.51	18.20	24.62	26.00	0.74	0.70
RB5	6.6	408	64.2	0.45	16.10	23.56	25.00	0.68	0.64

To utilize these equations after exposure to fire flame temperatures the relative between the values (M_u test/ M_u calculated) were calculated for the rigid beam specimens. At fire temperature (400°C), for the rigid beam specimens cooled by air, the ACI and B.S Building codes close results to predict bending moment capacity, while ACI Code gave overestimated values whereas, the B.S

Code gave well predicted results of beam moment capacity cooled by water. While, at fire temperature (750°C), for the beam specimens cooled by air and water, the ACI and B.S Building codes became unable to predict bending moment capacity. From the results, it is clear that the predicted ultimate bending moment capacity obtained from (ACI and B.S) Codes provisions is

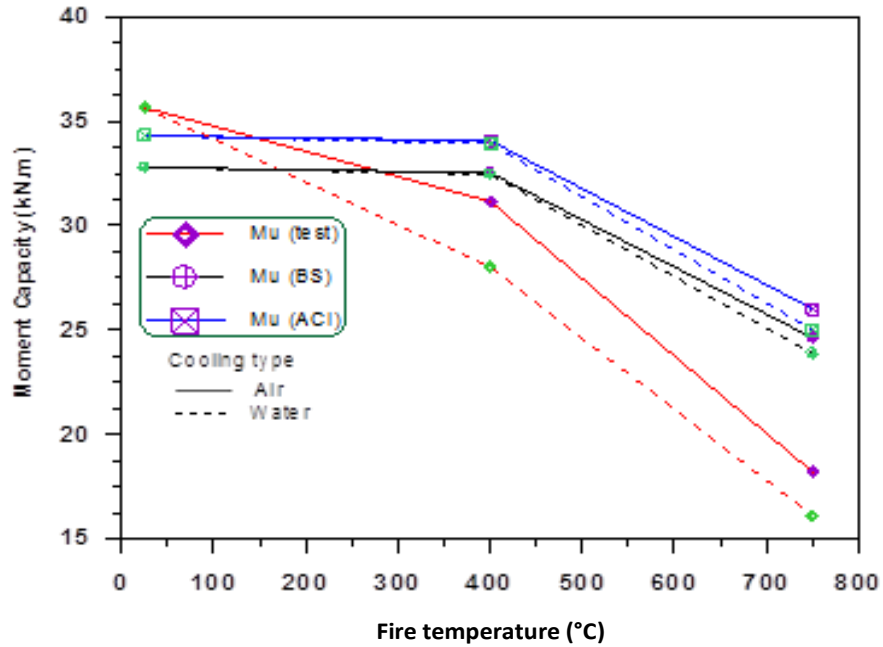

Figure 10. Comparison of ultimate moment (Mu) obtained from the experimental and from (ACI and B.S) Codes method.

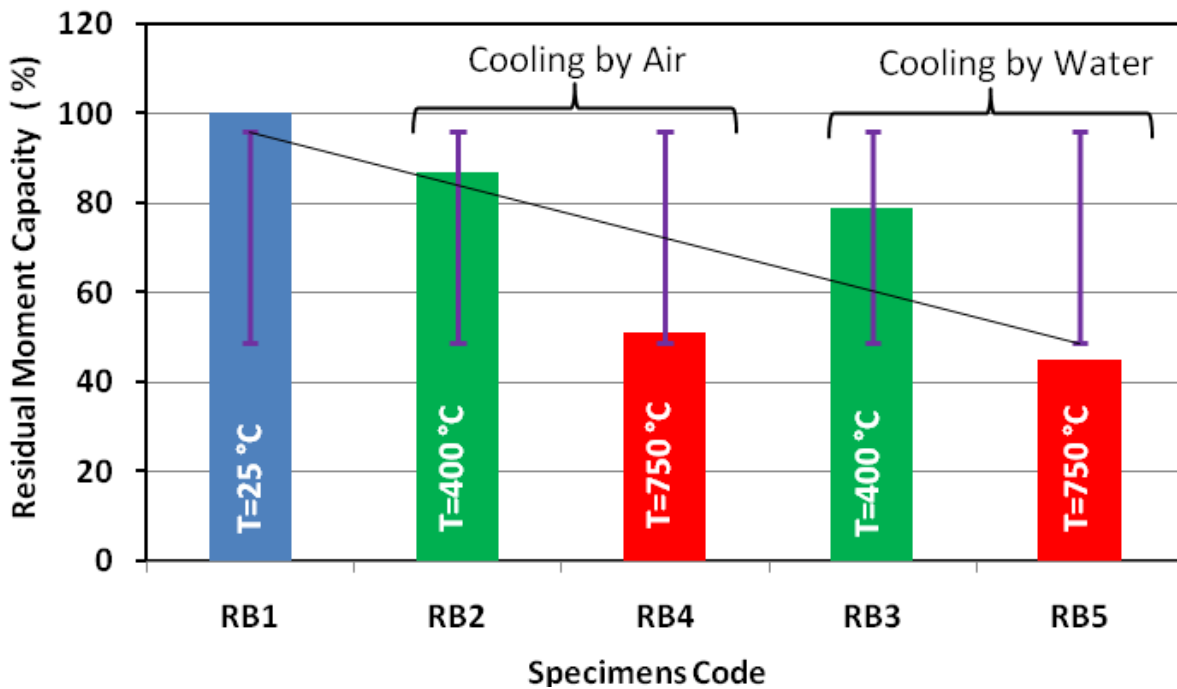

Figure 11. The decreases in residual moment capacity with fire

greater than that obtained in the experimental work after exposure o fir flame. This can be attributed to the precracking which happens upon burning.

Fire endurance of the tested rigid beams

The aim of design for fire safety should be to limit

damage due to fire. The unexposed surface of each tested beam was observed throughout (1.5 h) fire test. Fire resistance is defined in terms of the ability of the rigid beams to maintain their sustained service load for the required duration during exposure to the standard fire. Fire endurance periods are determined usually by physical tests conducted according to the provisions of ASTM E119-01(2001). Under this standard, the fire endurance of a member or assembly is determined by the time required to reach any of the following three end points:

- 1) The passage or propagation of flame to the unexposed surface of the test assembly;
- 2) A temperature rise of 163°C at a single point or 121°C as an average on the unexposed surface of the test assembly; and
- 3) Failure to carry the applied design load or structural collapse.

Based on the results of this work, it was noticed that the test results agreed with (ASTM E119-01). While, these beam specimens were subjected to fire flame temperatures of (400 and 750°C) for (90 min), the fire endurance of all the beam specimens investigated was reached when the inability to carry the applied design load, then these rigid beams were considered failed according to ASTM E119-01 (2001).

Temperature distribution of specimen section

It was found from the thermocouples readings at various points within the specimen (rigid beam), that the temperature distribution along the specimen length is basically the same, but significantly nonuniform along its cross section. The temperature distribution curves along the depth and cross the width at different exposure temperature are presented in Figure 12. Comparing between them, it can be found that the temperature distribution along the depth 30 and 60 mm from the specimen lateral surface are similar. When the fire flame (T°) is low ($T^\circ \leq 400^\circ\text{C}$), there is a significant temperature gradient along the section depth from the specimen soffit up to about 30 mm. Further upward the temperature gradient becomes much less and nearly tends to zero. When $T^\circ \leq 750^\circ\text{C}$, the temperature curve shapes are always concave forwards the origin. It should be noted that the temperature along the depth of the specimen always increases with rising temperature T° . The rate of burning was maintained at $10 \pm 1^\circ\text{C}/\text{min}$. Once the required maximum fire temperature was reached, the temperature was maintained until the specimens were removed. For all RC rigid beams, the total duration in the burning was 1.5 h.

Figure 13 reveals the average temperature histories for the RC beams. At the beginning, the beams are at room temperature, measured to be 25°C. The experimental

results clearly indicated that the temperature near the surface to fire is higher and decreases towards the top unexposed surface (Lie and Celikkol, 1991) have shown that this temperature behavior is due to the thermally-induced migration of moisture toward the center of the RC beams. The influence of moisture migration is the highest at the center of the RC beams. These results agreed with that obtained by (Kodur et al., 2005). But this temperature time curves is different from that given by the International Standard Organization (ISO) 834 (Figure 13). The temperature increase rate for the network methane burners is slower compared to the ISO834 curve. This is especially so at the initial period where the temperature difference between the two curves are the greatest. This will affect the fire resistance concrete members.

Crack pattern and mode of failure

In the heating process, two types of cracks developed, the first was thermal cracks appearing randomly in a honeycomb fashion all over the surface. They originated from top or bottoms edges and terminated near the mid-depth of the rigid beam. The crack width was about (1.2 mm). The patterns of fine cracks were consistent with the release of moisture being greater in the outer layers than in the interior resulting in differential shrinkage. These cracks were observed in rigid beam specimens during burning at about (15-24 min) of burning. The second cracks were flexural tensile cracking due to loading developed in the mid-span region. Flexural cracks appear initially in the constant moment region. Further, flexural cracks were formed progressively and widened as the loading increased. Scabbing occurred prior to the rigid beam failure due to the crushing of the concrete. The rigid beam specimens are failed with the typical flexural failure mode (yielding of steel followed by crushing of concrete). The mean crack width was about (2.8 mm).

The beam burnt at 400°C, the flexural cracks were wide speared along the beam outside the pure bending moment region. However inclined cracks are formed due to the presence of increasing shear stresses as the load and temperature increase. For rigid beams burnt at 750°C, additional vertical cracks appeared on the beam surface, followed by formation of diagonal cracks, the failure began outside the mid span of beam. Figure 14 shows photographs for crack patterns for the rigid beams before and after exposure to fire flame.

Fire testing observations for rigid beam specimens

During the tests, special attention was drawn to visual observations. The followings are some of the observations that were recorded:

- (i) During the experimental test, the beam was monitored

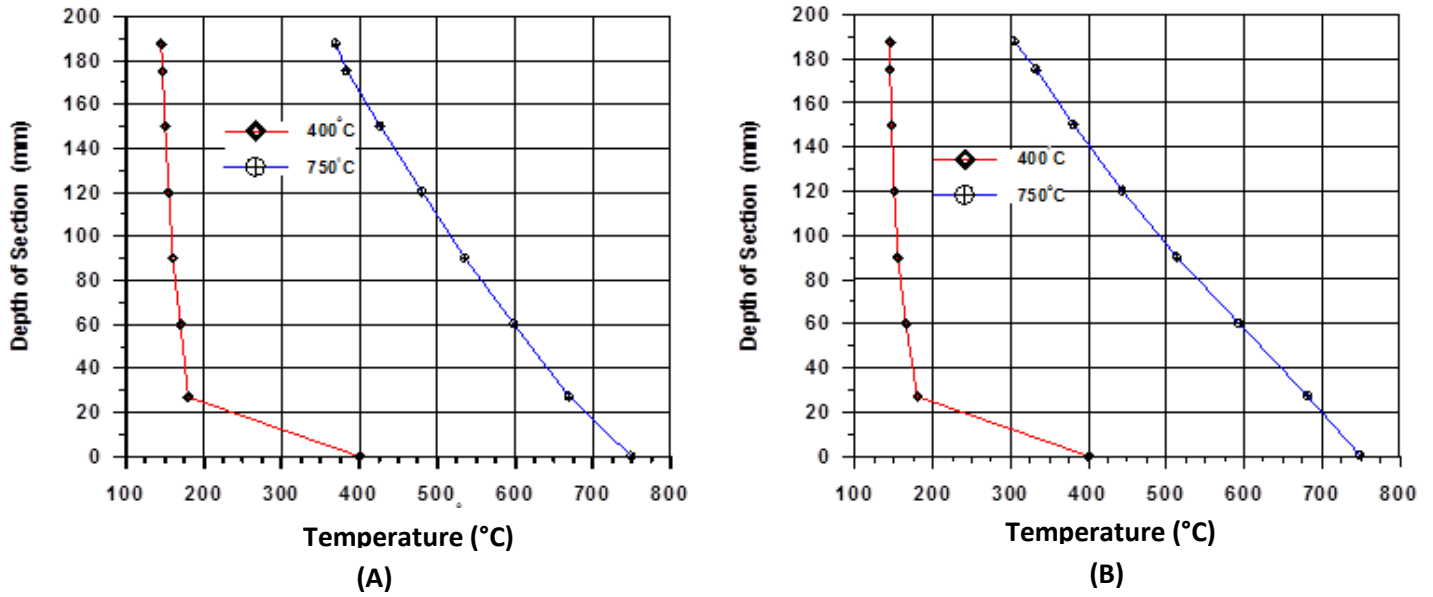

Figure 12. Temperature distributions along section depth at (A) 30mm and (B) 60mm from lateral surfaces.

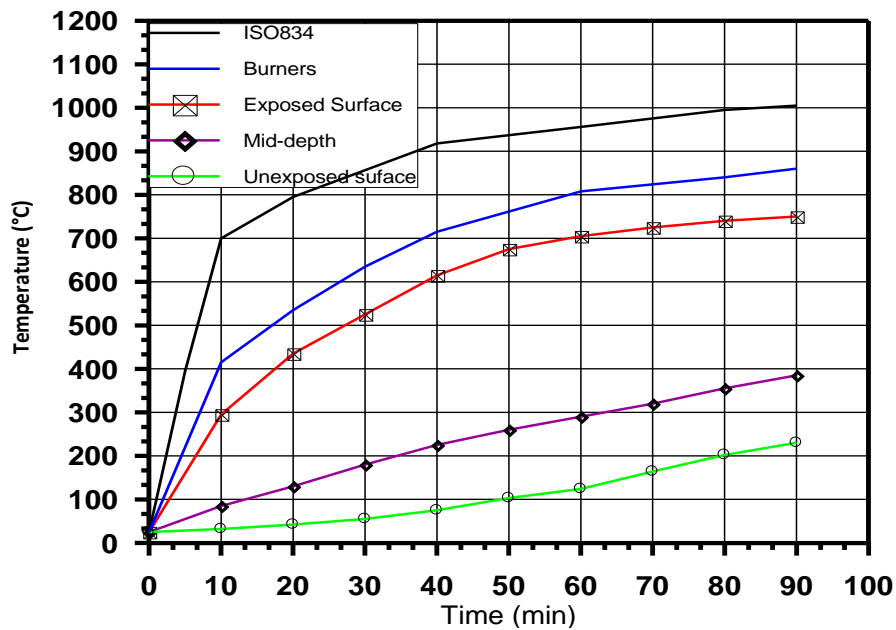

Figure 13. Temperatures recorded at various locations in RC beam RB4 as a function of fire exposure time.

continuously for development of surface cracks. It was observed that the surface cracks formed earlier than expected, at approximately 23 and 12 min during burning to temperature 400 and 750°C respectively. These cracks eventually led to spalling of concrete cover, when the specimens were loaded after burning.

(ii) After the beams were subjected to fire flame, two types of cracks developed, and the first was thermal

cracks appearing randomly in a honeycomb fashion all over the surface. They originated from top or bottoms edges and terminated near the mid-depth of the rigid beam. The crack width was about (1.5 mm). The patterns of fine cracks were consistent with the release of moisture being greater in the outer layers than in the interior resulting in differential shrinkage. The second cracks were flexural tensile cracking due to loading

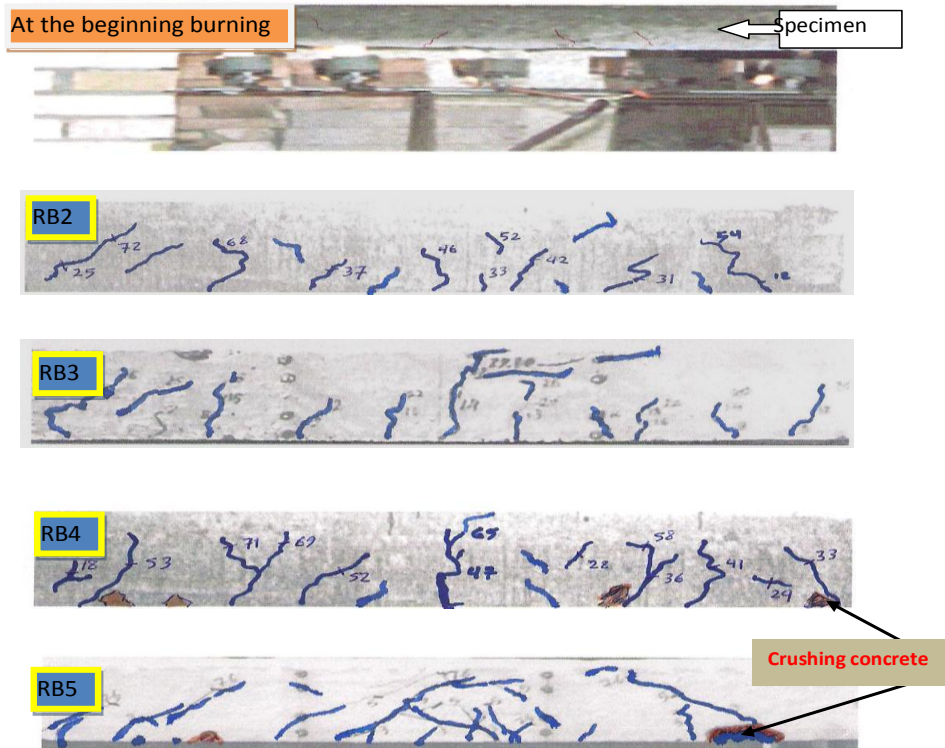

Figure 14. Typical crack pattern of rigid beam specimens before and after burning and subjected to loading.

developed in the mid-span region.

(iii) These cracks were observed in rigid beam specimens during burning at about (15-24 min) of burning.

(iv) Generally, runoff water from all surfaces of beam specimens in the first few minutes was noticed. This phenomenon was observed at about 10-15 min and continued for approximately 9 minutes for all burning temperatures 400 and 750°C. This can be attributed to the increase in vapor pressure inside the saturated voids which causes water to escape out from the cracks on the surface generated by fire exposure.

Conclusions

Based on the experimental studies completed so far, the following conclusions can be drawn:

(1) The ultrasonic pulse velocity tested showed a response to the effect of fire flame, the reduction in (U.P.V) was (28 and 33%) and (52 and 54%) for beams cooled in air and water at 400 and 750°C respectively. It appears that this non-destructive test gives good predicted values for the residual strength.

(2) The reduction in rebound number was (22 and 27%) and (42 and 45%) for beams cooled in air and water at

400 and 750°C respectively. The decrease in the rebound number with increasing in fire temperature can be attributed to the fact that fire causes damage to the surface of concrete rigid beams rather than to concrete in the core of the member.

(3) Sudden cooling concrete caused additional strength loss for RC beam specimens.

(4) It was found that the ultimate load capacity of rigid beam specimens decreases significantly when subjected to burning by fire flame.

(5) In this study, it is noticed that the load-deflection relation of RC rigid beam specimens exposed to fire flame temperature around 750°C are more leveled indicating softer load-deflection behavior than that of the control beams. This can be attributed to the early cracks and lower modulus of elasticity.

(6) The ACI and B.S Codes predict ultimate moment capacity after exposure to 750°C fire flame temperature conservatively.

(7) The experimental results clearly indicate that the crack width in reinforced concrete beams that are subjected to fire flame are higher than the beams that are not burned at identical loads.

(8) Fire temperature has significant effect on the flexural performance of RC rigid beams. The ultimate and serviceable bearing capacities of RC specimens decrease with the increase of fire temperature.

Conflict of Interest

The author(s) have not declared any conflict of interest.

REFERENCES

- ACI 318-08 (2008). Building code requirements for reinforced concrete. American Concrete Institute, Detroit.
- ACI Committee 211 (1997). Standard practice for selecting proportions for normal, heavyweight, and mass concrete (ACI211.1-91). American Concrete Institute, Michigan, U.S.A.
- ACI Committee 216 R-89 (1994). Guide for determining the fire endurance of concrete elements. ACI Committee 216.
- ASTM, Test Method E119-01 (2001). Standard methods of fire test of building construction and materials. American Society for Testing and Materials, West Conshohocken, PA.
- Bazant ZP, Kaplan MF (1996). Concrete at high temperatures. Material Properties and Mathematical Models. Longman Group Ltd.
- BS-8110 part 2 (1997). Design curves of concrete strength with temperature.
- Choi EG, Shin YS (2011). The structural behavior and simplified thermal analysis of normal-strength and high-strength concrete beams under fire. *Eng. Struct.* 33:1123-1132.
- Elghazouli AY, Cashell KA, Izzuddin BA (2009). Experimental evaluation of the mechanical properties of steel reinforcement at elevated temperature. *Fire Safety J.* 44(6):909-919.
- El-Hawary MM, Ragab AM, El-Azim AA, Elibiari S (1996). Effect of fire on flexural behavior of RC beams. *Constr. Build. Mater.* 10(2):147-150.
- El-Hawary, MM, Ragab A M, El-Azim AA, Elibiari, S (1997). Effect of fire on shear behavior of RC beams. *J. Appl. Fire Sci.* 65(2):281-287.
- Gruz CR (1966). Elastic properties of concrete at high temperature. *J. PCA Res. Dev. Lab.* 8(1):37-45.
- Hsu HJ, Lin CS (2006). Residual bearing capabilities of fire-exposed reinforced concrete beams. *Int. J. Appl. Sci. Eng. Chaoyang University of Technology*, ISSN 1727-239.
- Hsu, JH, Lin CS, Hung CB (2006). Modeling the effective elastic modulus of RC beams exposed to fire. *J. Marine Sci. Technol.* 14: 2:1-7.
- Huang ZH (2011). The behaviour of reinforced concrete slabs in fire. *Fire Safety J.* 45:271-282.
- Iraqi Organization of Standards, IOS 45 (1984a). Aggregate from natural sources for concrete and construction. Ministry of Planning Central Organization for Standardization and Quality Control.
- Iraqi Organization of Standards, IOS 5 (1984b). Portland cement. Ministry of Planning, Central Organization for Standardization and Quality Control.
- Kodaira A, Fujinaka H, Ohashi H, Nishimura T (2004). Fire resistance of composite beams composed of rolled steel profile concreted between flanges. *Fire Sci. Technol.* 23(3):192-208.
- Kodur VKR, Dwaikat MB (2008). Effect of fire induced spalling on the response of reinforced concrete beams. December, *Int. J. Concrete Structures Mater.* 2(2):71-81.
- Kodur VRK, Bisby LA, Green MF, Chowdhury E (2005). Fire endurance experiments on FRP-strengthened reinforced concrete columns. National Research Council of Canada, Institute for Research in Construction, Res. Report No.185, March. 41pages.
- Kong FK, Evans RH, Cohen E, Rall F (1983). Handbook of structural concrete. McGraw-Hill, New York.
- Kowalski R, Krol P (2010). Experimental examination of residual load bearing capacity of RC beams heated up to high temperature. Structures in Fire-Proceedings of the Sixth International Conference, Michigan, June.
- Lie TT, Celikkol B (1991). Method to calculate the fire resistance of circular reinforced concrete columns. *ACI Materials J.* pp. 84-91.
- Lin TD (1985). Measured temperature in concrete beams exposed to ASTM E 119 standard fire. Research and Development Report. Portland Cement Association. Skokie.
- Neville AM (1995). Properties of concrete. Longman Group, Ltd., 4th and Final Edition, P. 388.
- Phani PDMS, Kumar V, Sharma UK, Bhargava P (2010). Moment curvature relationships for fire damaged reinforced concrete sections. Structures in Fire- Proceedings of the Sixth International Conference, Michigan, June.
- Schneider U (1988). Concrete at high temperatures - A general review. *Fire Safety J.* 13(1):55-68.
- Shetty MS (1988). Concrete technology theory and practice. Third Edition, P. 361.
- Smith EE, Harmathy TZ (1979). Design of building for fire safety. American Society for Testing and Materials, Philadelphia.
- Uddin T, Culver CG (1975). Effect of elevated temperature on structure members. *J. Structural Div. ASCE.* 101:1531-1549.



Journal of Civil Engineering and Construction Technology

Related Journals Published by Academic Journals

- *International Journal of Computer Engineering Research*
- *Journal of Electrical and Electronics Engineering Research*
- *Journal of Engineering and Computer Innovations*
- *Journal of Petroleum and Gas Engineering*
- *Journal of Engineering and Technology Research*
- *Journal of Civil Engineering and Construction Technology*

academicJournals